

HYDRANTULA FITTING CATALOGUE 2024

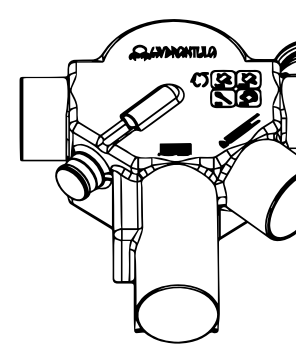

PART 3 H3 family

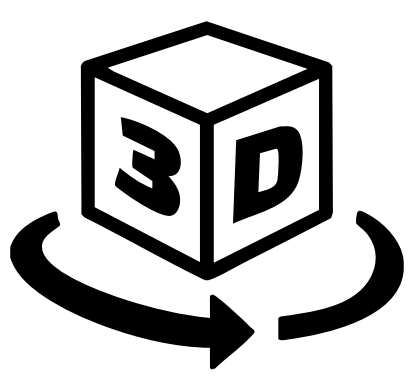
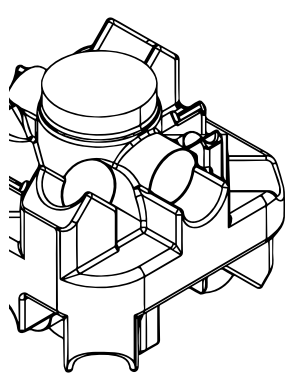
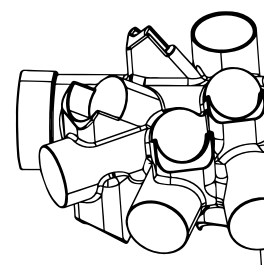
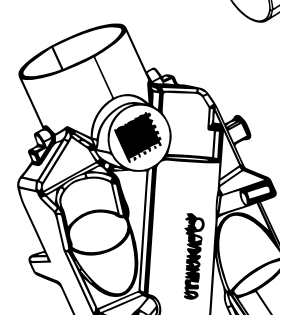
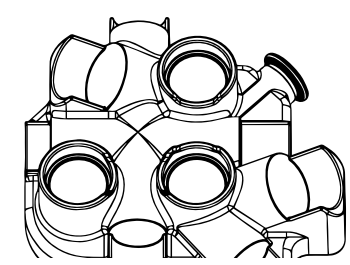
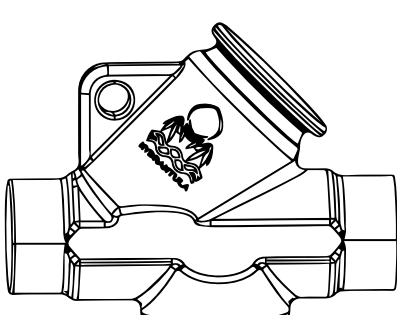
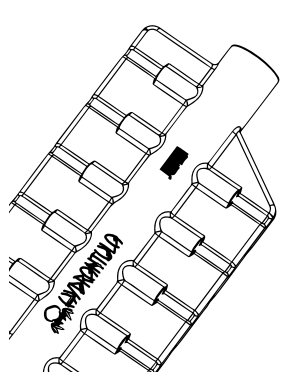
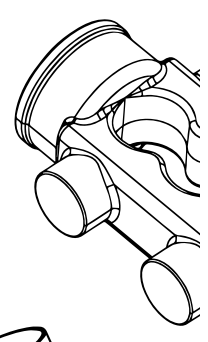

H3

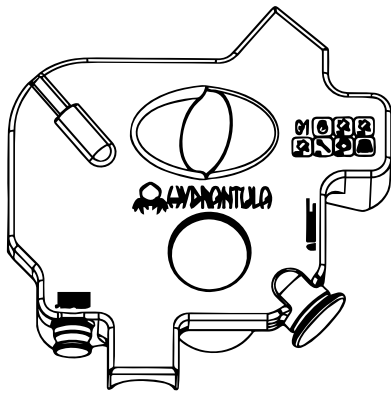

G1

G1

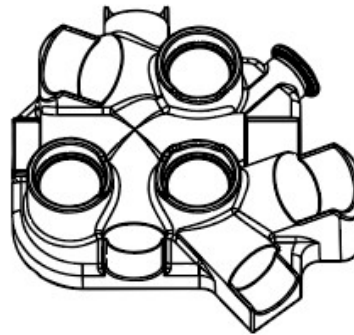

WEIGHT: **12.8 kg**
CAPACITY: **61.3 L**
MEASURES: **770x230x665 mm**

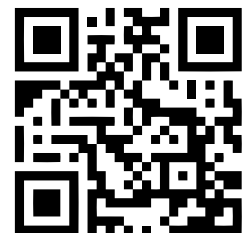

COMPATIBLE : **M13, M11, X32, DS1, N2*, D3***

H3

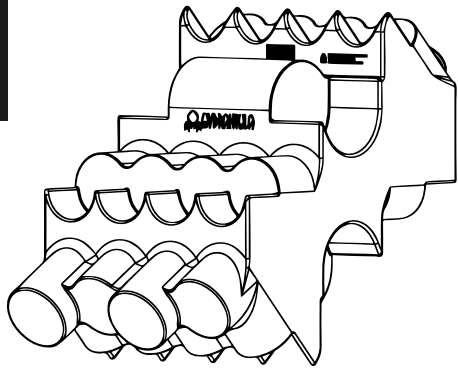

X11

X11

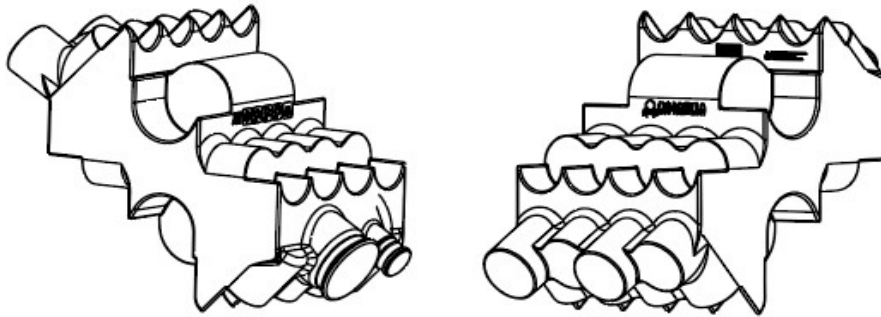

WEIGHT: **14.73 kg**
CAPACITY: **86.8 L**
MEASURES: **485x890x305 mm**

COMPATIBLE : **X32, M11, D2***



H3

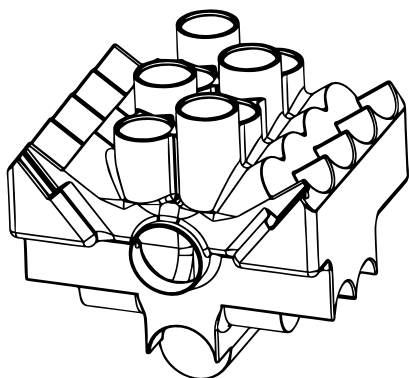

X31

X31

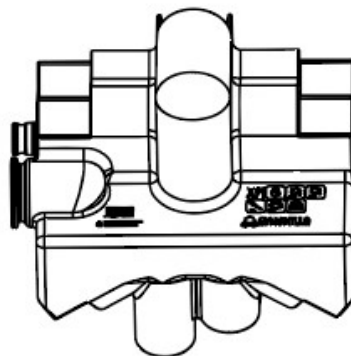
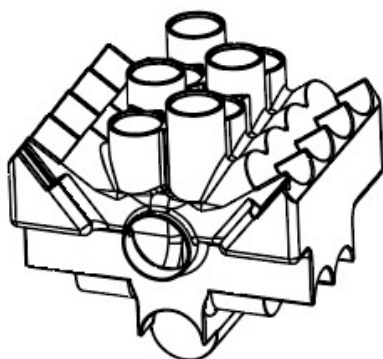

WEIGHT: **21.23 kg**
CAPACITY: **146.7 L**
MEASURES: **721x817x578 mm**

COMPATIBLE : **X32, M11, M13, D2***



H3

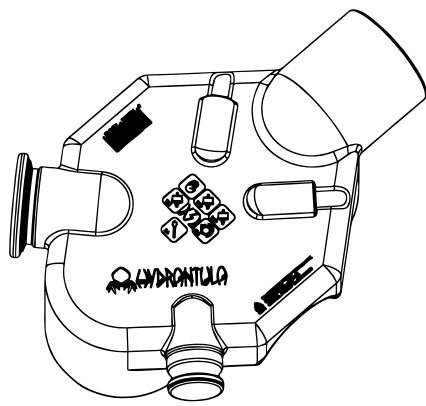

X32

X32

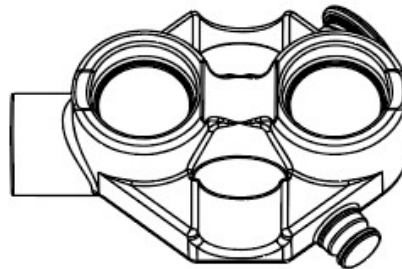

WEIGHT: **5.9 kg**
CAPACITY: **23.9L**
MEASURES: **590x430x255 mm**

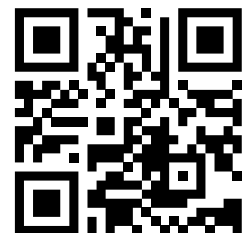

COMPATIBLE : **X11, U45, X31, G1, D3***

H3

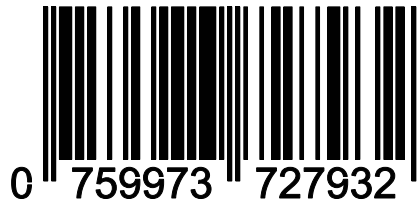
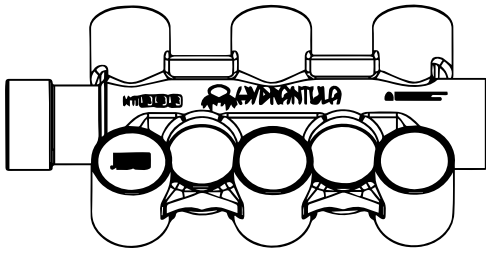

M11

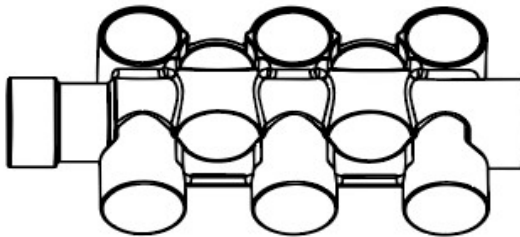

M11

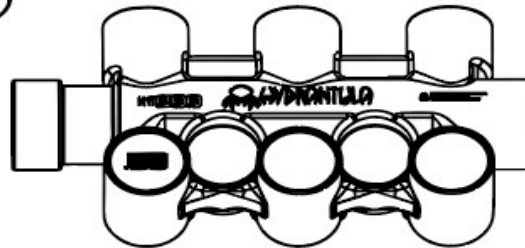

WEIGHT: **7.99 kg**
CAPACITY: **32.6 L**
MEASURES: **395x821x200 mm**

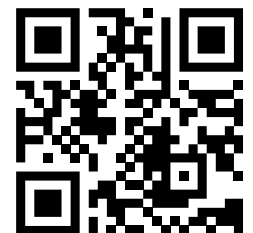

COMPATIBLE : **X11, X31, U45, X32, G1**

H3

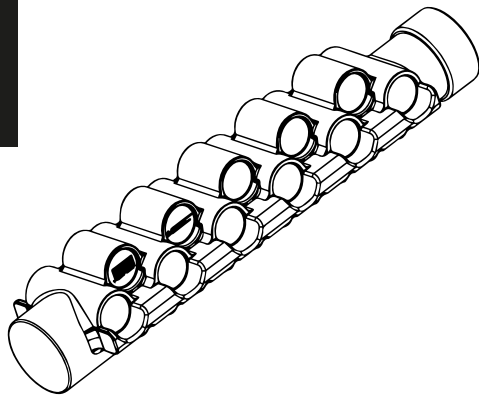

M13

M13

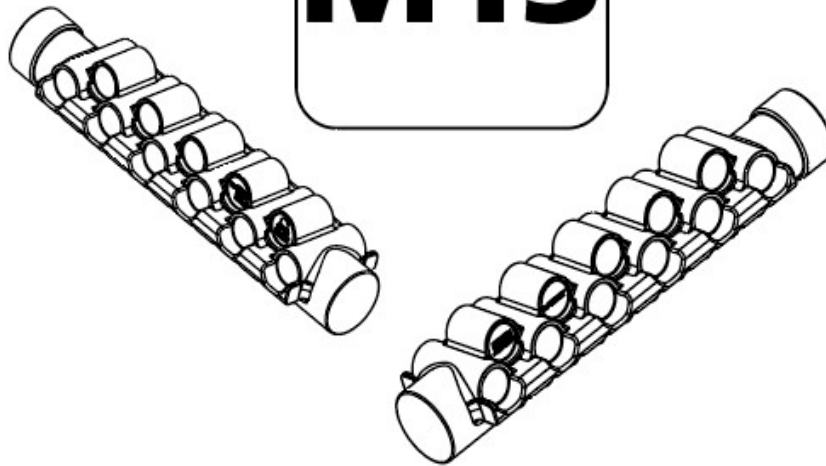

WEIGHT: **7.91 kg**
CAPACITY: **30.3 L**
MEASURES: **1070x280x200 mm**

COMPATIBLE : **U45, G1, X31**



H3

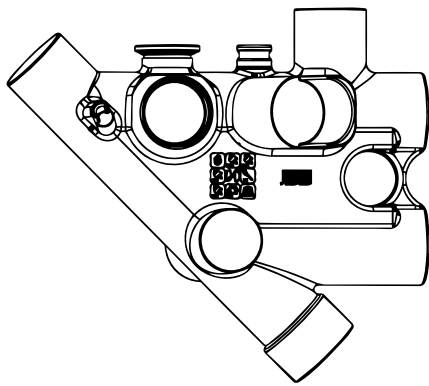

U45

U45

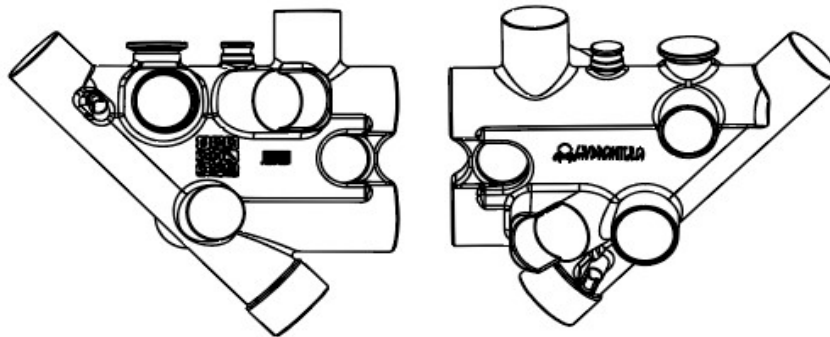

WEIGHT: **13.6 kg**
CAPACITY: **70.6 L**
MEASURES: **910x690x350 mm**



COMPATIBLE : **X32, M11, M13, D3*, N2*, N5²**

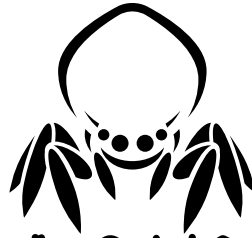
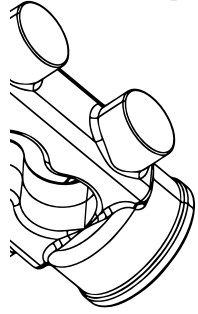
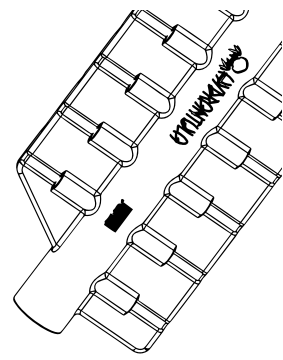
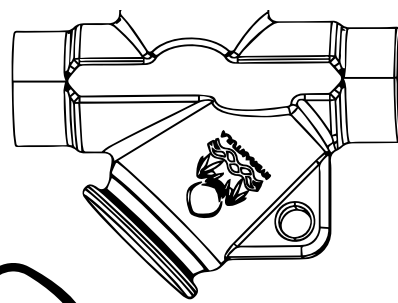
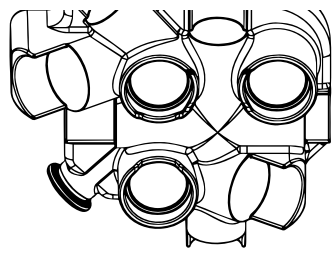
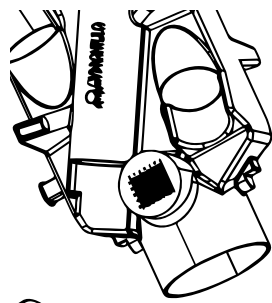

HYDRANTULA

HYDRANTULA FITTING CATALOGUE 2024

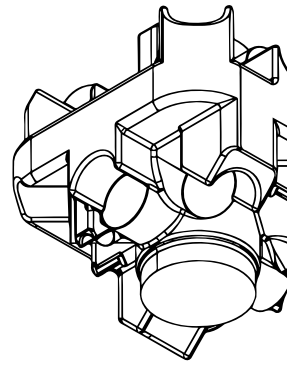
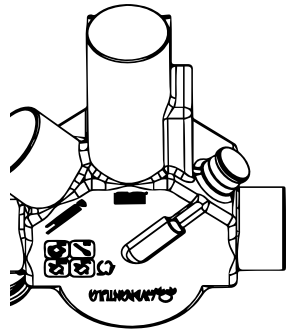
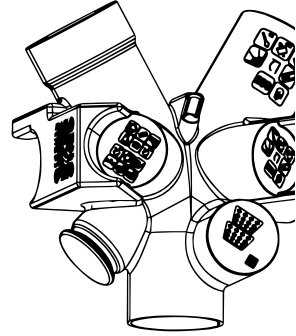

+7 966 275-55-58



hydrantula



olegkuchma5



sales@hydrantula.com



+79662755558



hydrantula



hydrantu.la



olegkuchma5



hydrantula.com



olegkuchma5



oleg-kuchma-70a601277



hydrantula.de