

HYDRANTULA FITTING CATALOGUE 2024

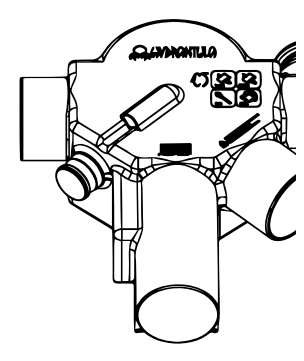

PART 1 H0 & H1 family

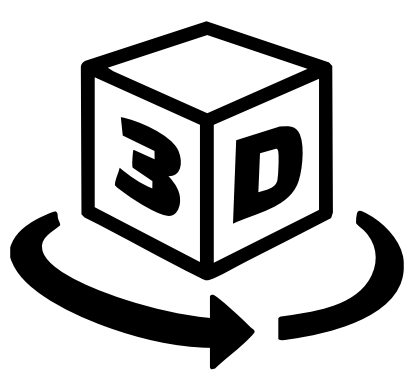
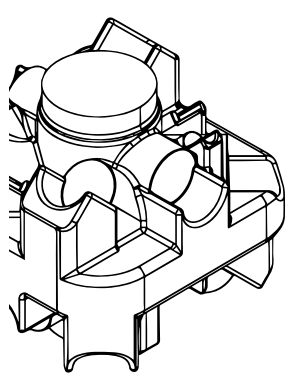
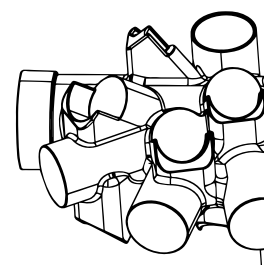
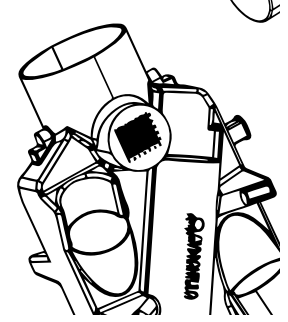
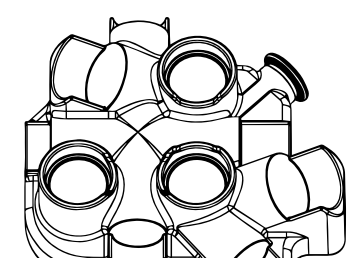
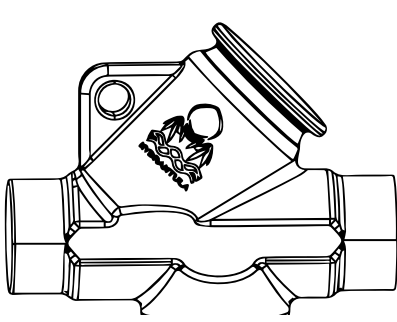
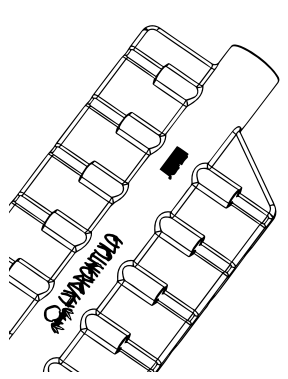
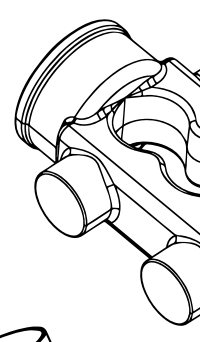

H0

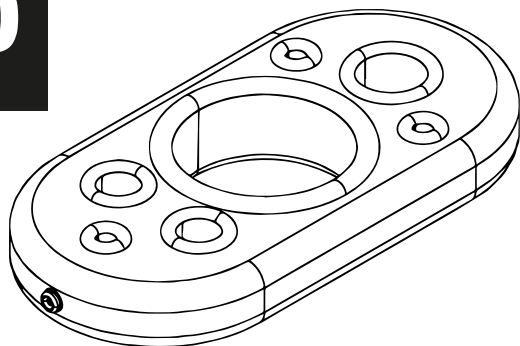

DUCKER

DUCKER

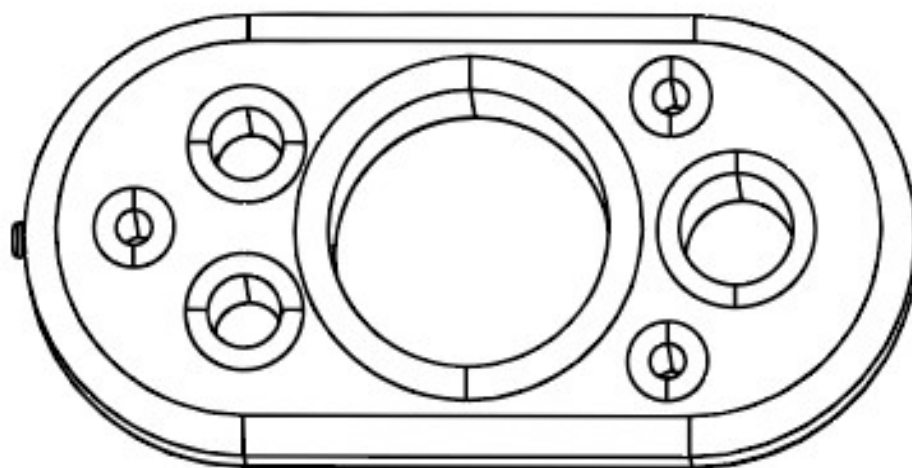

WEIGHT: **0.85 kg**

CAPACITY: **1.7 L**

MEASURES: **407x67x202 mm**

COMPATIBLE : **ALL**

H0

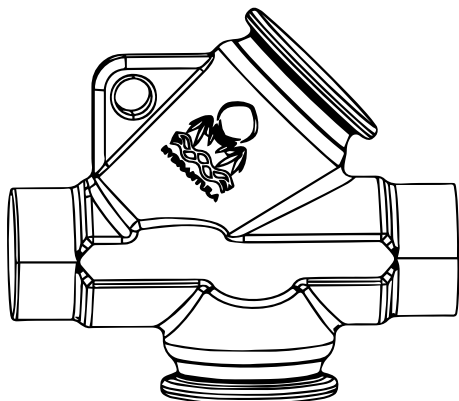

D2

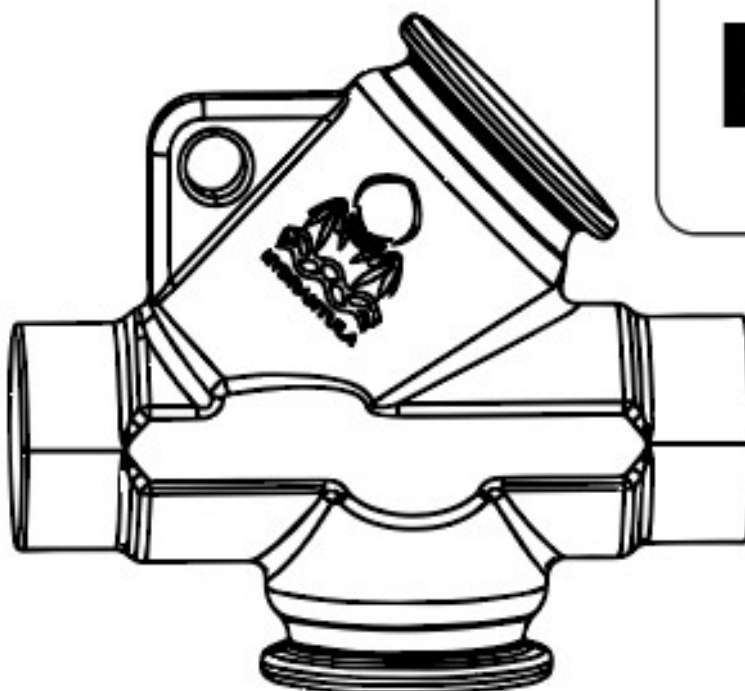

D2

WEIGHT: **2.5 kg**
CAPACITY: **26 L**
MEASURES: **369x423x170 mm**



COMPATIBLE : **B61, A16, A18, A36, X31, X11, U45, S3, Y4, L2**

H0

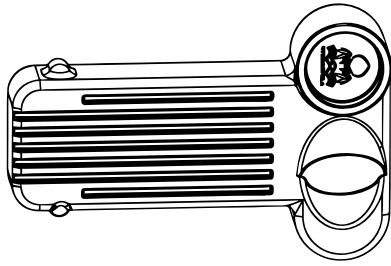

DS1

DS1

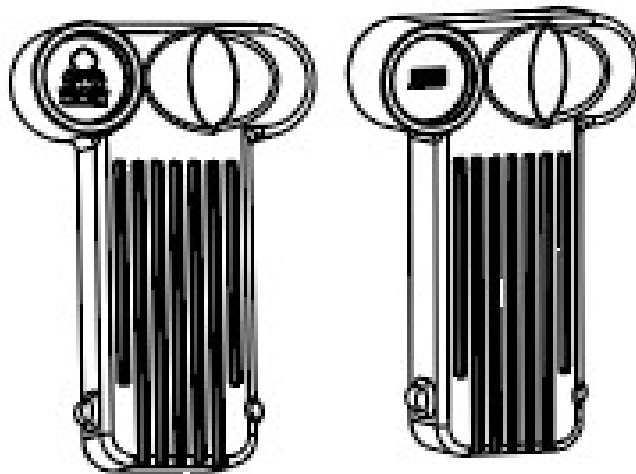

WEIGHT: **6.76 kg**
CAPACITY: **26 L**
MEASURES: **702x464x241 mm**

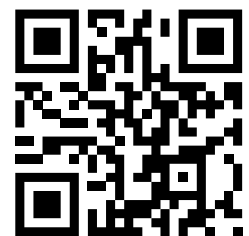

COMPATIBLE : **A16, A18, A36, G1, U45**

H0

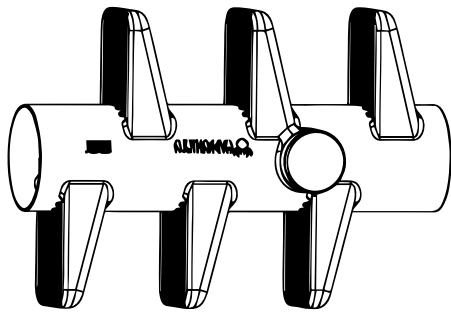

DS6

DS6

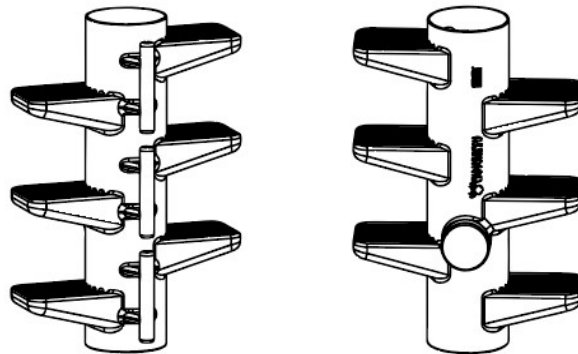

WEIGHT: 19.33 kg
CAPACITY: 107.5 L
MEASURES: 1130x750x438 mm

COMPATIBLE : B61, B62, A16, A18, A36, C5, D2*



H1

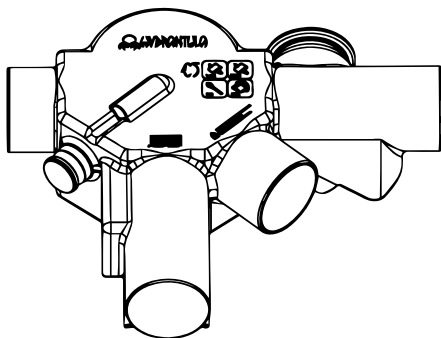

C5

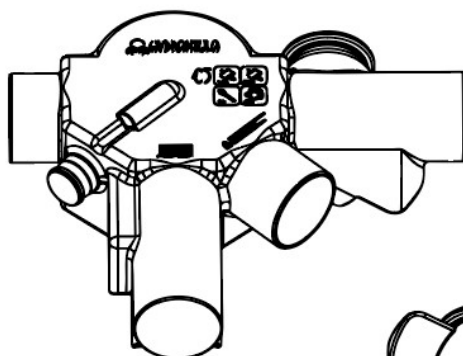

C5

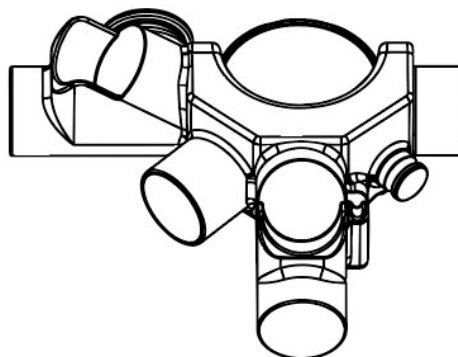

WEIGHT: **9.19 kg**
CAPACITY: **41.8 L**
MEASURES: **704x291x806 mm**

COMPATIBLE : **D2*, DS6*, N2***



H1

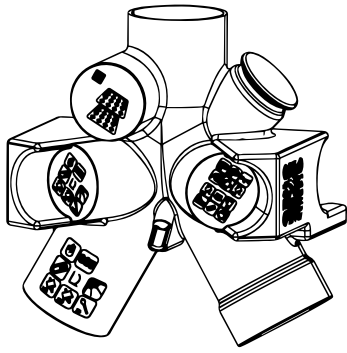

L2

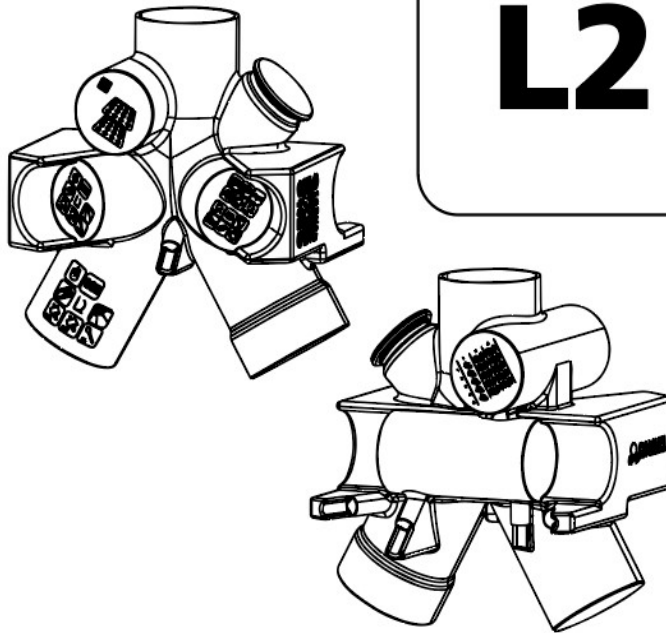

WEIGHT: **14 kg**
CAPACITY: **143.5 L**
MEASURES: **750x540x560 mm**

COMPATIBLE : **L1, L3, D2***



H1

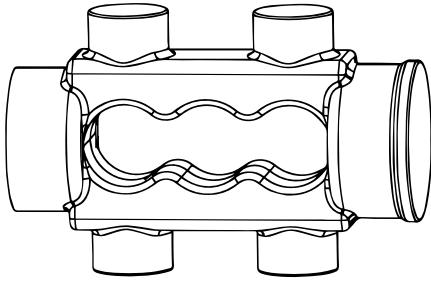

L3

L3

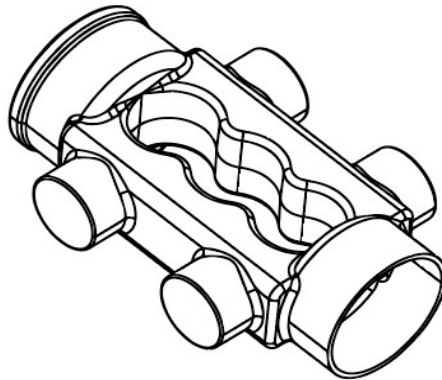

WEIGHT: **7.85 kg**
CAPACITY: **54 L**
MEASURES: **240x410x640 mm**

COMPATIBLE : **L2, L1**



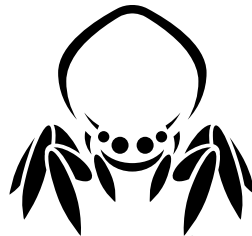
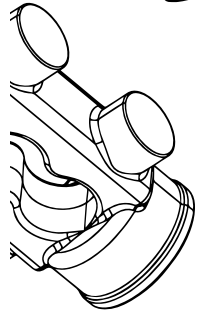
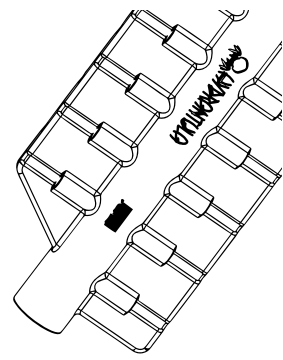
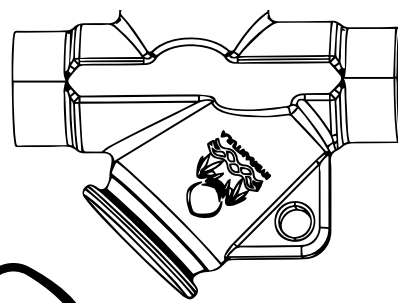
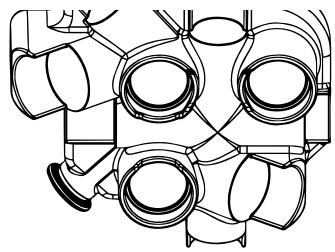
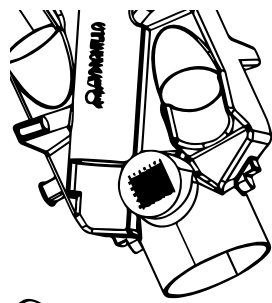

HYDRANTULA

HYDRANTULA FITTING CATALOGUE 2024

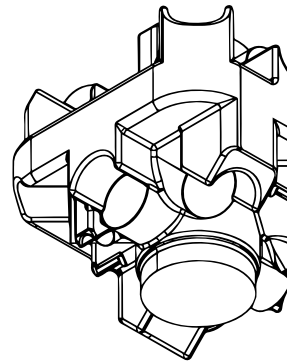
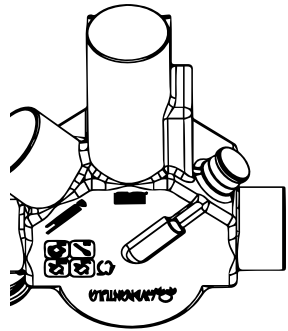

+7 966 275-55-58



hydrantula



olegkuchma5



sales@hydrantula.com



+79662755558



hydrantula



hydrantu.la



olegkuchma5



hydrantula.com



olegkuchma5



oleg-kuchma-70a601277



hydrantula.de